

**GRAND RAPIDS CHARTER TOWNSHIP  
REGULAR TOWNSHIP MEETING  
1836 EAST BELTLINE N.E.**

**January 16, 2018  
7:00 p.m.**

**AGENDA**

1. Pledge of Allegiance.
2. Brief Public Comment. (Brief 2-3 minutes per person relating to agenda items).
- \*3. Approve minutes of the regular Township Board meeting of January 2, 2018.
- \*4. Consider bills to be paid.
- \*5. Consider approval to purchase monitors and carts.
- \*6. Discussion of draft 5 year parks and recreation plan.
7. Board Comments.
8. Public Comments. (Please limit comments to less than 5 minutes and state your name and address for the recording secretary)
9. Adjournment.

**GRAND RAPIDS CHARTER TOWNSHIP  
REGULAR TOWNSHIP BOARD MEETING  
January 2, 2018**

A meeting of the Grand Rapids Charter Township Board was called to order at 7:00 pm by Supervisor Michael DeVries. The meeting was held in the Township Hall. The following were present: Supervisor Michael DeVries, Clerk Edward Robinette, Treasurer David Van Dyke, and Trustees, David Pierangeli, Lee Van Popering, and Philip Yeiter. Trustee Vas Christopoulos was absent. There was one person in the audience.

**1. PLEDGE OF ALLEGIANCE.**

**2. BRIEF PUBLIC COMMENT.** There were none.

**3. APPROVE MINUTES OF THE REGULAR TOWNSHIP BOARD MEETING OF DECEMBER 19, 2017.**

Lee Van Popering, seconded by David Pierangeli, moved approval of the minutes as presented. The motion passed unanimously.

**4. CONSIDER CASH DISBURSEMENTS.**

Lee Van Popering, seconded by Philip Yeiter, moved approval of the cash disbursements as presented. The motion passed unanimously.

**5. CONSIDER BILLS TO BE PAID.**

Lee Van Popering, seconded by David Pierangeli, moved approval of the bills as presented. The motion passed unanimously.

**6. CONSIDER APPROVAL OF THE AMENDMENTS TO THE MEDICAL EXPENSE REIMBURSEMENT AND THE PERSONNEL POLICY.**

Lee Van Popering, seconded by David Pierangeli, moved approval of the amendments as presented. The motion passed unanimously.

**7. CONSIDER APPROVAL FOR AN OUTDOOR ASSEMBLY PERMIT FOR A REQUESTED EVENT AT CRAHEN VALLEY PARK.**

Lee Van Popering, seconded by Philip Yeiter, moved approval of the Outdoor Assembly Permit as requested. The motion passed unanimously.

**8. CONSIDER APPROVAL OF THE \$15,000 EXPENDITURE TO PURCHASE LAND FROM MDOT.**

Lee Van Popering, seconded by David Van Dyke, moved approval of the expenditure as presented. The motion passed unanimously.

**9. BOARD COMMENTS.** There were none.

**10. PUBLIC COMMENTS.** Ken Fortier introduced himself as a candidate for State Representative.

**11. ADJOURNMENT.** The meeting was adjourned at 7:15 pm.

BD

Claimant	Amount Claimed	Amount Owed	Amount Rejected
1. LAKE MI CREDIT UNION	29,275.13		
***TOTAL ALL CLAIMS***	29,275.13		

BD

BOTH OPEN AND PAID

Claimant	Amount Claimed	Amount Owed	Amount Rejected
1. ABSOPURE WATER CO	66.75		
2. APPLIED IMAGING	661.72		
3. CONSUMERS LIFE INSURANCE COMPANY	252.06		
4. COVERALL OF WEST MICHIGAN	253.00		
5. DEVEREAUX, ROBERT	44.28		
6. DEVRIES, MICHAEL	6,048.78		
7. FIRE PROS INC.	82.40		
8. FOUR SEASONS YARD & SPORT	12.97		
9. HOLST, JANICE	400.00		
10. HYDRO-TURF IRRIGATION	3,357.50		
11. INT'L INST OF MUN CLERKS	160.00		
12. KCI	963.10		
13. KENT COUNTY CLERKS ASSOCIATION	30.00		
14. KENT COUNTY EMERGENCY MED	237.54		
15. KENT RECORD MANAGEMENT INC	202.43		
16. LEGAL BRIEFINGS FOR FIRE CHIEFS	99.00		
17. LOWE'S	49.84		
18. LUSCIOUS LANDSCAPES	595.00		
19. MDOT	15,000.00		
20. NETWORKFLEET, INC	113.70		
21. ORKIN INC	81.60		
22. SHELDON CLEANERS	13.50		
23. SPECTRUM HEALTH OCCU SVCS	3,755.00		
24. STATE INDUSTRIAL PRODUCTS	182.90		
25. STATE OF MICHIGAN	240.00		
26. TECH MASTERS	4,915.57		
27. TENDER LAWN CARE	4,248.00		
28. VANDUINEN ELEVATOR CO.	67.50		
29. VERSLUYS, ROBERT	1,816.00		
***TOTAL ALL CLAIMS***	43,950.14		

MICHAEL J. DeVRIES  
SUPERVISOR

EDWARD J. ROBINETTE  
CLERK

DAVID A. VAN DYKE  
TREASURER



LEE VANPOPERING  
TRUSTEE

DAVID M. PIERANGELI  
TRUSTEE

BEVERLY S. WALL  
TRUSTEE

PHILIP D. YEITER  
TRUSTEE

Item # 5

January 16, 2018

TO: Grand Rapids Charter Township Board of Trustees

FROM: Michael J. DeVries  
Township Supervisor

RE: Updated monitors and carts purchase

RECOMMENDATION

Consider approval of purchase of updated monitors and carts in the amount of \$12,947.17.

BACKGROUND

See attached.



1425 Coit Ave NE  
Grand Rapids, MI 49505

Phone 616.458.2999  
Fax 616.458.6524

# Quotation

Grand Rapids Township  
1836 East Beltline NE  
Grand Rapids, MI 49525

12/27/2016

Proposed Ship Date	Person Contacted	Phone #	Customer PO#
	Bob VerSluys	855-5809	
Qty	Each	Extended	
<b>Audience Displays on Carts</b>			
<p>Central Interconnect will provide and install 2 new 70" Display Systems on mobile carts. The signal to the displays will be wireless so that all they will need is an AC Power Cable to a wall outlet. The existing projectors will be removed and the screens will be abandoned in place. The system will be fully warranted for 1 year for parts and labor.</p>			
<b>Audience Displays</b>			
2	Synnex / Sharp PN-E703	70" Sharp Aquos LED TV System	
2	Chief PFCUB	Large Flat Panel Mobile AV Cart	
0			
<b>Wireless HDMI to Carts</b>			
1	Extron 60-1490-02	eLink 100 T US Wireless HDMI Extender - Transmitter	
2	Extron 60-1490-03	eLink 100 T US Wireless HDMI Extender - Receiver	
2	Middle Atlantic #29674	HDMI Cable w/ Gripping Connectors 1.5'	
0			
<b>Remove Existing Projectors</b>			
1	Central Labor	Remove Existing Projectors	
<b>Total Sale Price</b>			<b>\$12,947.17</b>
Applicable Taxes Included			

\* Cancellations Subject to a 20% Restocking Charge  
This quotation is hereby accepted on this date \_\_\_\_\_  
and submitted as an order.

Quote is Valid for 30 Days

Accepted by: Name & Title \_\_\_\_\_

Michael J. Smith  
Direct 616-732-1034

### Slimline LED Displays That Meet Diverse Signage Needs



These 70-inch-class (69.5" diagonal) and 60-inch-class (60.1" diagonal) Sharp monitors combine full-HD image quality, stylishly thin profiles and energy efficiency to create appealing professional signage solutions for a wide range of applications. With their sleek design, around-the-clock operation, and support for landscape and portrait installations, these displays offer an amazing degree of flexibility. In hotel lobbies, conference rooms, retail spaces and elsewhere, the PN-E703/E603 will grab and keep the attention of your target audience.

#### Superb Image Quality

PN-E703/E603 LCD panels incorporate Sharp's **UV<sup>2</sup>A<sup>+</sup>** technology, which prevents light leakage and ensures highly efficient use of light from the backlight. Thanks to this technology, the monitors achieve truly bright whites and extremely deep blacks. Both models support full-HD (1080p) resolution, for beautifully clear rendering of detailed text and graphics.

\* UV<sup>2</sup>A stands for **U**ltraviolet-induced **M**ulti-domain **V**ertical **A**lignment, a photo-alignment technology that ensures uniform alignment of liquid crystal molecules.

#### Thin, Lightweight Design

PN-E703/E603 monitors owe their exceptionally thin profiles to edge-lit LED backlighting. Streamlined for a pleasing appearance and minimal protruding parts, these monitors measure just **1 9/16"** at their thickest point and weigh only **94.8 lbs / 70.5 lbs**, making for easy placement in offices, public spaces, stores, and other commercial establishments.





**FEATURES**

- 1 CENTRIS® FINGERTIP TILT**  
Effortlessly adjust display using Centris fingertip tilt technology. Screen angle stays set until you decide to readjust.
- 2 TELESCOPING HEIGHT ADJUSTMENT**  
Integrated knob provides tool-less telescoping adjustment from 4 ft (122 cm) to 6 ft (180 cm).
- 3 CLICKCONNECT® LATCHING**  
Hear an audible click when the screen engages with the mount. Easy to connect/disconnect - no tools needed!
- 4 PORTRAIT/LANDSCAPE CAPABILITY**  
Mounts in either portrait or landscape position.
- 5 CABLE MANAGEMENT**  
Flexible covers hide cables for a clean installation.

**WHAT YOU NEED TO KNOW**

**OTHER PRODUCT OPTIONS**



**MFC**  
 Mobile Cart  
 Height: 4 - 6' (122 - 180 cm), Tilt: ±15°



**PFM**  
 Confidence Monitor Cart  
 Height: 3 - 4' (91 - 122 cm), Tilt: +15°/+45°



**PFQ**  
 Confidence Monitor Cart  
 Height: 2 - 2.5' (61 - 76 cm), Tilt: +15°/+45°

**SPECIFICATIONS**

Dimensions* (HxWxD)	80.25" x 37.13" x 32.13" (204 x 94.3 x 81.6 cm)
Height	4 - 6' (122 - 180 cm)
Tilt	±15°
Weight Capacity	200 lbs (90.7 kg)
Colors	Black, Silver

\* Dimensions do not include interface bracket

**RECOMMENDED ACCESSORIES**



**PAC710** ■ Accessory Shelf



**PAC720** ■ Dual Display Accessory

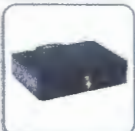

**PAC730** ■ Secure Storage Shelf

**TECHNICAL DRAWINGS**

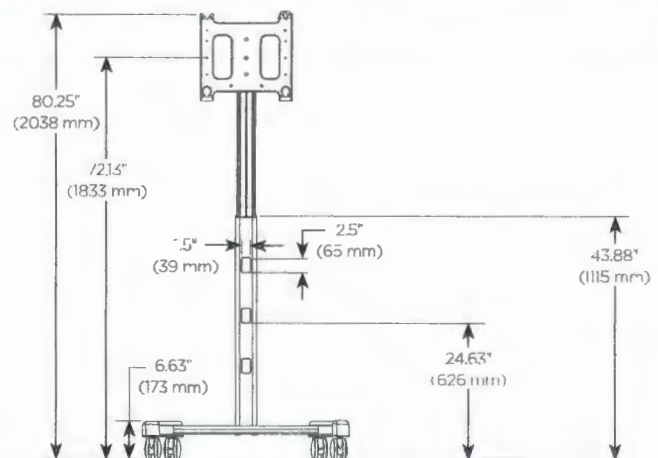

For a complete list of cart & stand accessories see pages 93 - 94.



MICHAEL J. DeVRIES  
SUPERVISOR

EDWARD J. ROBINETTE  
CLERK

DAVID A. VAN DYKE  
TREASURER



LEE VANPOPERING  
TRUSTEE  
DAVID M. PIERANGELI  
TRUSTEE  
BEVERLY S. WALL  
TRUSTEE  
PHILIP D. YEITER  
TRUSTEE

Item # 6

January 16, 2018

TO: Grand Rapids Charter Township Board of Trustees  
FROM: Michael J. DeVries  
Township Supervisor  
RE: Draft 5 year plan

RECOMMENDATION

Discussion of draft 5 year parks and recreation plan.

BACKGROUND

See attached plan.